

**VITRIFIED / RESIN BONDED DIAMOND / CBN AND DIAMOND IMPREGNATED CERAMIC BARS**

**SHANK  $\phi 6.0$  Resin Bond**  
1 pc./pack

Diamond	15101	15102	15103	15104	15105
CBN	15111	15112	15113	15114	15115

**SHANK  $\phi 2.34$**   
12 pcs./pack Assorted Set

15301	
Set (12 pieces) (Each code No. one piece-pack)	
11204	11313
11208	11321
11213	11333
11242	11356
11247	11366
11250	11502

**SHANK  $\phi 3.0$**   
12 pcs./pack Assorted Set

15305	
Set (12 pieces) (Each code No. one piece-pack)	
12317	12403
12320	12405
12336	12412
12341	12415
12355	12451
12401	12492

**SHANK  $\phi 3.0$**   
10 pcs./pack Assorted Set

15311			
Set (10 pieces) (Each code No. one piece-pack)			
$\phi$ mm	CAT. NO.	$\phi$ mm	CAT. NO.
0.8	12009	3	12058
1	12051	3.5	12060
1.5	12053	4	12061
2	12055	5	12063
2.5	12057	6	12065

15312			
Set (10 pieces) (Each code No. one piece-pack)			
$\phi$ mm	CAT. NO.	$\phi$ mm	CAT. NO.
0.8	12019	3	12158
1	12151	3.5	12160
1.5	12153	4	12161
2	12155	5	12163
2.5	12157	6	12165

**SHANK  $\phi 3.0$**   
8 pcs./pack Assorted Set

15321			
Set (8 pieces) (Each code No. one piece-pack)			
$\phi$ mm	CAT. NO.	$\phi$ mm	CAT. NO.
1	14752	3	14756
1.5	14753	4	14758
2	14754	5	14759
2.5	14755	6	14760

15322			
Set (8 pieces) (Each code No. one piece-pack)			
$\phi$ mm	CAT. NO.	$\phi$ mm	CAT. NO.
1	14792	3	14796
1.5	14793	4	14798
2	14794	5	14799
2.5	14795	6	14800

**SHANK  $\phi 3.0$**   
8 pcs./pack Assorted Set

15331			
Set (8 pieces) (Each code No. one piece-pack)			
$\phi$ mm	CAT. NO.	$\phi$ mm	CAT. NO.
1.5	15071	3.5	15075
2	15072	4	15076
2.5	15073	5	15077
3	15074	6	15078

15332			
Set (8 pieces) (Each code No. one piece-pack)			
$\phi$ mm	CAT. NO.	$\phi$ mm	CAT. NO.
1.5	15081	3.5	15085
2	15082	4	15086
2.5	15083	5	15087
3	15084	6	15088

**CARBIDE CUTTERS**

Tool / Cut types and features (\*' Shows available shank sizes for each cut type)

<p><b>Single Cut (1)</b></p> <p>Single cut produces superior surface finishes. * <math>\phi 1.6, \phi 2.34, \phi 3.0, \phi 6.0</math></p>	<p><b>Single Cut Coarse (2)</b></p> <p>Single Cut Coarse has similar cutting characteristics to Single cut, but is better for gummy materials due to deep helix design. Ideal for rubbers, resins, and plasters. * <math>\phi 2.34, \phi 3.0</math></p>	<p><b>Chip Breaker (3)</b></p> <p>Chip Breaker is the single cut with a chip breaker. The chip breaker clears chips easily making aggressive cutting very efficient. Surface finish is rougher than single cut. * <math>\phi 1.6, \phi 2.34</math></p>	<p><b>Alumina Cut (4)</b></p> <p>Alumina Cut has very sharp edge with a deep helix. The deep helix design prevents tool loading. Ideal for aluminum, magnesium alloys, plastics and hard rubbers. * <math>\phi 6.0</math></p>
<p><b>Double Cut (5)</b></p> <p>Smooth Cut with small tooth design minimizes chatter. This tool also helps enhance safety as it produces very small chips. * <math>\phi 2.34, \phi 3.0, \phi 6.0</math></p>	<p><b>Double Cut Coarse (6)</b></p> <p>Deep helix design prevents tool loading. Ideal for grinding hard rubbers, resins and plaster. * <math>\phi 2.34</math></p>	<p><b>Diamond Cut Fine (7)</b></p> <p>Diamond Cut Fine (7) has similar characteristics as Double Cut (5). Specially designed for very hard materials. Produces fine surface finish. * <math>\phi 2.34, \phi 3.0</math></p>	<p><b>Diamond Cut Coarse (8)</b></p> <p>Specially designed for very hard materials. Produces fine surface finish. * <math>\phi 3.0, \phi 6.0</math></p>

Titanium coating insures long tool life and minimizes tool loading.

**SHANK  $\phi 3.0$**   
1 pc./pack Double Cut

$\phi 3$	$\phi 6.3$	$\phi 1.5$	$\phi 3$	$\phi 6.3$	$\phi 3$	$\phi 6.3$	$\phi 3$	$\phi 6.3$	$\phi 3$	$\phi 6.3$	$\phi 3$	$\phi 6.3$	$\phi 3$	$\phi 6.3$	$\phi 2.2$	$\phi 3$
21201	21205	21211	21212	21213	21215	21216	21222	21223	21231	21235	21241	21242	21245	21251	21252	

**SHANK  $\phi 3.0$**   
1 pc./pack Double Cut

$\phi 5$	$\phi 3$	$\phi 3$	$\phi 6.3$	$\phi 3$	$\phi 3$	$\phi 6.3$
21253	21261	21262	21265	21271	21272	21275

**SHANK  $\phi 3.0$**   
1 pc./pack Single Cut

$\phi 2.1$	$\phi 3$	$\phi 5$	$\phi 6.3$	$\phi 1.4$	$\phi 2.5$	$\phi 3$
21291	21311	21292	21312	21293	21315	21294

**SHANK  $\phi 3.0$**   
1 pc./pack Single Cut

$\phi 6.3$	$\phi 6.3$	$\phi 3$	$\phi 3$	$\phi 3$	$\phi 6.3$	$\phi 6.3$	$\phi 3$	$\phi 3$	$\phi 6.3$	$\phi 6.3$
21295	21316	21296	21318	21319	21297	21299	21321	21322	21323	21324

Diamond / CBN Carbide Cutters Specialty Tools Mounted Points Rubberized Abrasives Flap Wheels Polishing Brushes Felt Bobs Abrasive Compounds & Polishing Tools NSK Exclusive Tools

Diamond / CBN Carbide Cutters Specialty Tools Mounted Points Rubberized Abrasives Flap Wheels Polishing Brushes Felt Bobs Abrasive Compounds & Polishing Tools NSK Exclusive Tools



**CARBIDE CUTTERS**

SHANK  $\phi 6.0$

1 pc./pack **Double Cut**

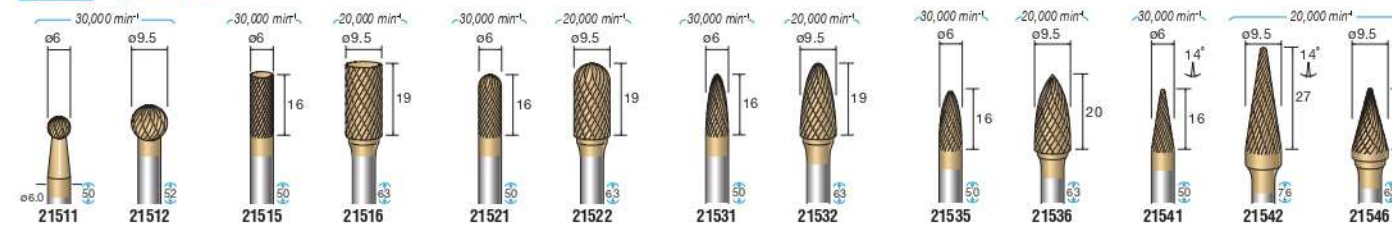

SHANK  $\phi 6.0$

1 pc./pack **Single Cut**



1.6 mm shank diameter series.  
Short type for high speed rotation.  
Best for grinding very small parts.

SHANK  $\phi 1.6$

5 pcs./pack **Single Cut** Round Type



SHANK  $\phi 1.6$

5 pcs./pack **Single Cut** Straight Type

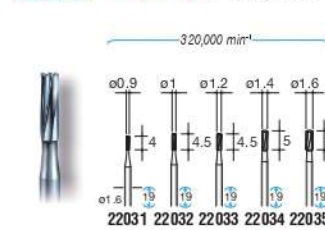

5 pcs./pack **Chip Breaker** Straight Type

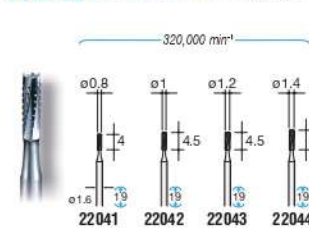

5 pcs./pack **Single Cut** Ball Tip Straight Type

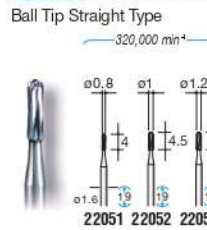

5 pcs./pack **Chip Breaker** Ball Tip Straight Type

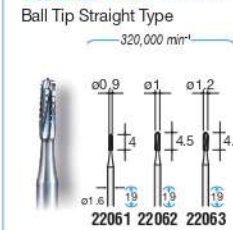

5 pcs./pack **Double Cut** Ball Tip Straight Type

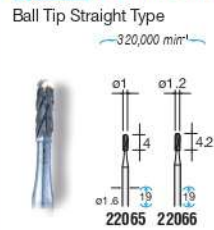

SHANK  $\phi 1.6$

5 pcs./pack **Single Cut** Tapered Type

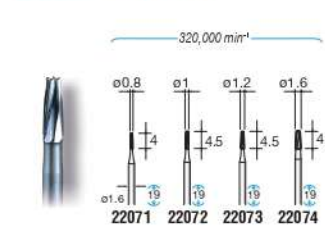

5 pcs./pack **Chip Breaker** Tapered Type

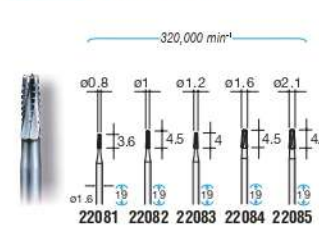

5 pcs./pack **Single Cut**



5 pcs./pack **Single Cut**

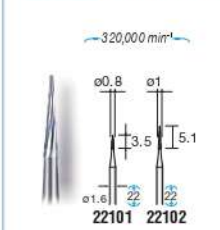

5 pcs./pack **Double Cut** Ball Point Tapered Type



SHANK  $\phi 1.6$

5 pcs./pack **Single Cut**

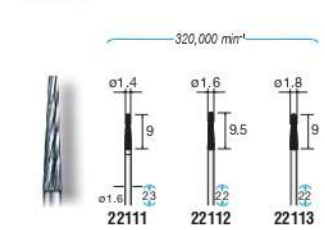

5 pcs./pack **Single Cut**

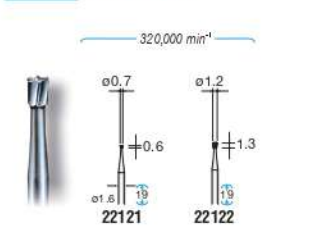

**CARBIDE CUTTERS**



2.34 mm shank diameter series.  
Ideal for engraving, and high precision burr removal.

SHANK  $\phi 2.34$

1 pc./pack **Single Cut**

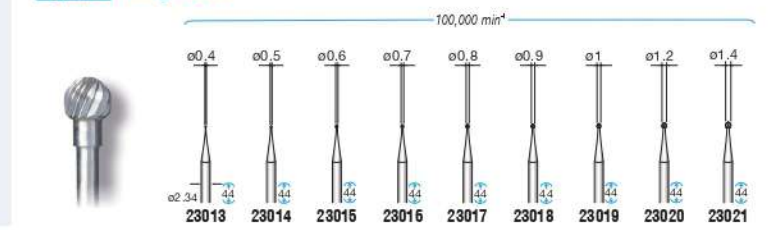

SHANK  $\phi 2.34$

1 pc./pack **Single Cut**

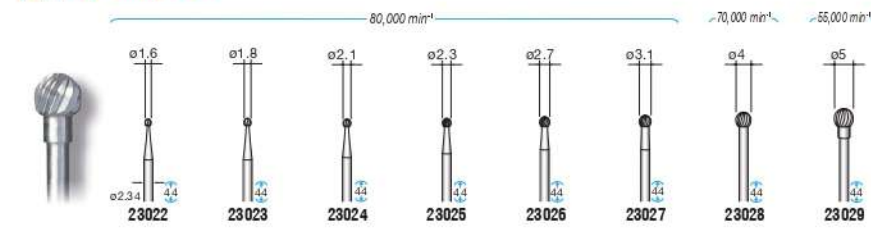

1 pc./pack **Double Cut**



SHANK  $\phi 2.34$

1 pc./pack **Single Cut**



1 pc./pack **Diamond Cut**



1 pc./pack **Diamond Cut**



1 pc./pack **Single Cut** End Cut

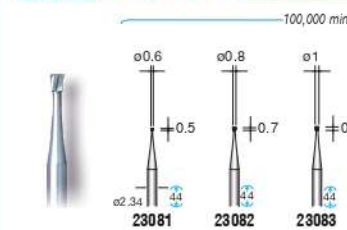

1 pc./pack **Diamond Cut** End Cut



SHANK  $\phi 2.34$

1 pc./pack **Single Cut** Straight Type

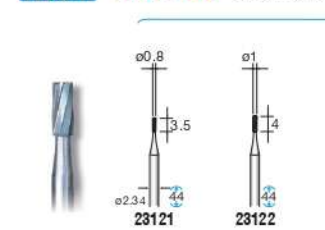

1 pc./pack **Single Cut** Tapered Type



SHANK  $\phi 2.34$

1 pc./pack **Single Cut** Ball Tip Straight Type

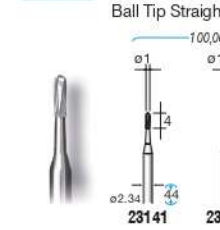

1 pc./pack **Single Cut** Ball Tip Tapered Type

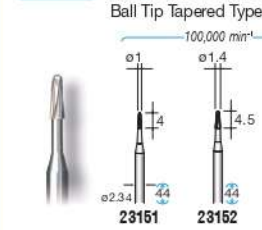

1 pc./pack **Chip Breaker** Straight Type

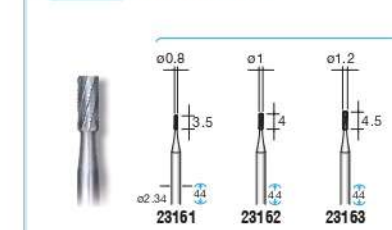

SHANK  $\phi 2.34$

1 pc./pack **Chip Cut** Tapered Type



1 pc./pack **Chip Cut** Ball Tip Straight Type

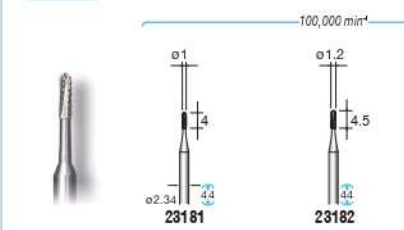

Diamond / CBN Carbide Cutters Speciality Tools Mounted Points Rubberized Abrasives Flap Wheels Polishing Brushes Felt Bobs Abrasive Compounds & Polishing Tools NSK Exclusive Tools

Diamond / CBN Carbide Cutters Speciality Tools Mounted Points Rubberized Abrasives Flap Wheels Polishing Brushes Felt Bobs Abrasive Compounds & Polishing Tools NSK Exclusive Tools



**CARBIDE CUTTERS**

SHANK  $\phi 2.34$

1 pc./pack Single Cut

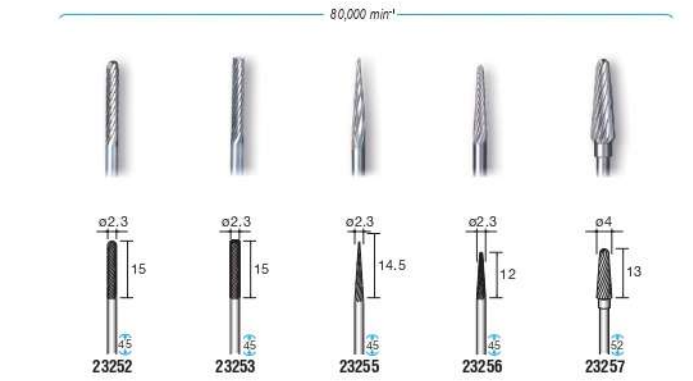

1 pc./pack Single Cut

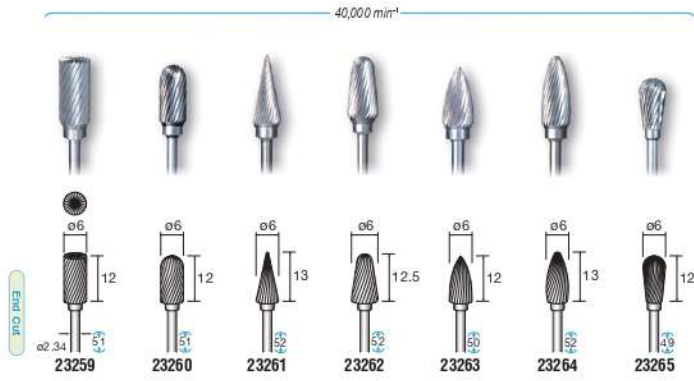

SHANK  $\phi 2.34$

1 pc./pack Single Cut

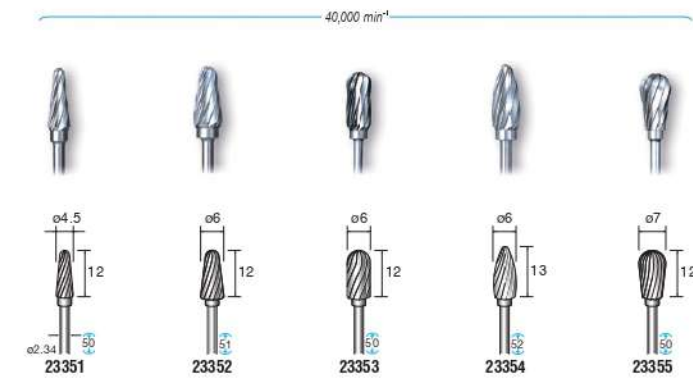

1 pc./pack Double Cut

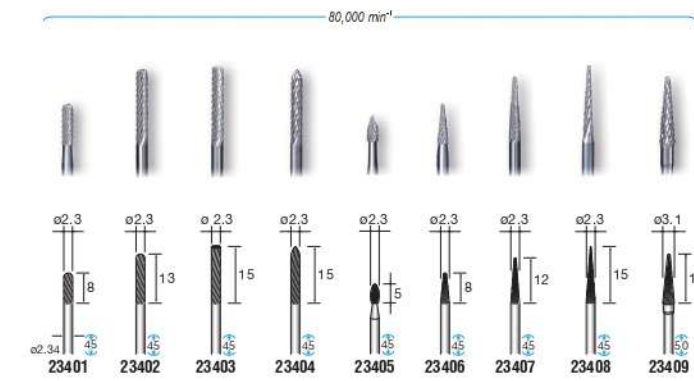

SHANK  $\phi 2.34$

1 pc./pack Double Cut

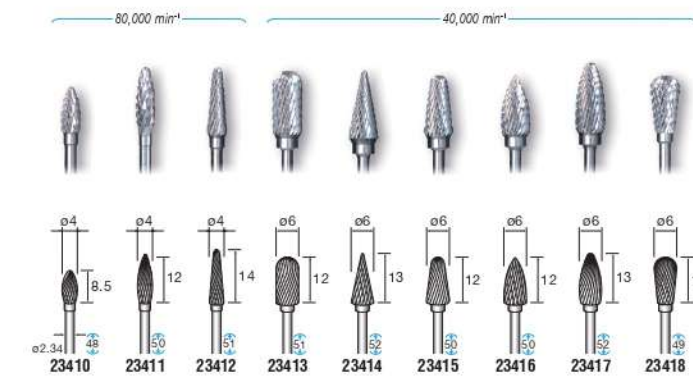

1 pc./pack Diamond Cut <Fine>

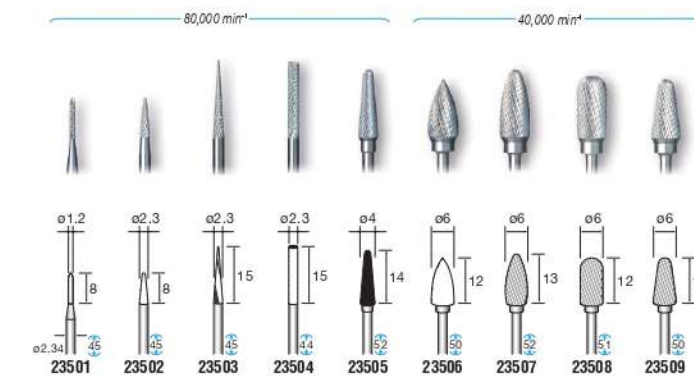

SHANK  $\phi 2.34$

1 pc./pack Double Cut <Rough>

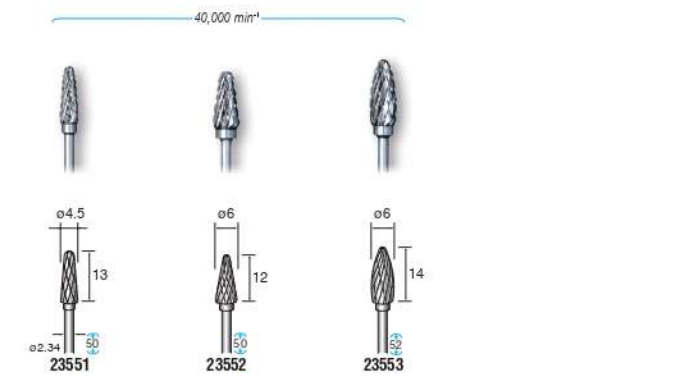

1 pc./pack Double Cut <Super Rough>

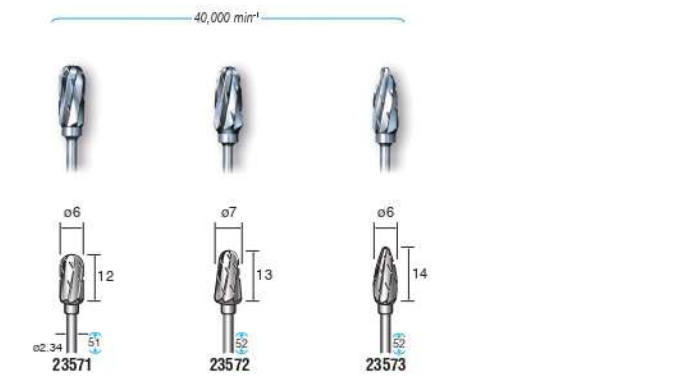

**CARBIDE CUTTERS** - Orange code numbers indicate Titanium-Coated Type.



3.0 mm shank diameter series. High quality carbide cutters offer superior durability and produce fine surface finishes.

SHANK  $\phi 3.0$

1 pc./pack Single Cut

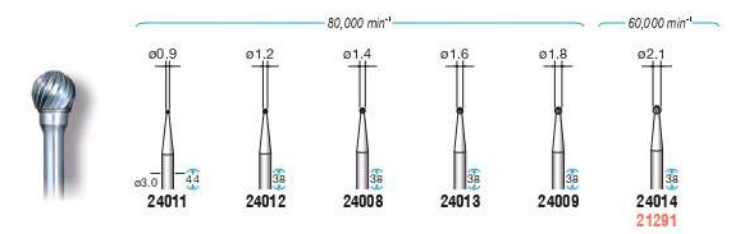

SHANK  $\phi 3.0$

1 pc./pack Single Cut

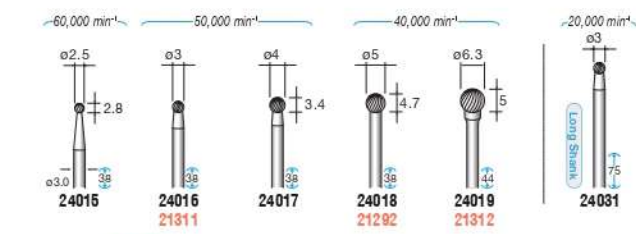

1 pc./pack Double Cut

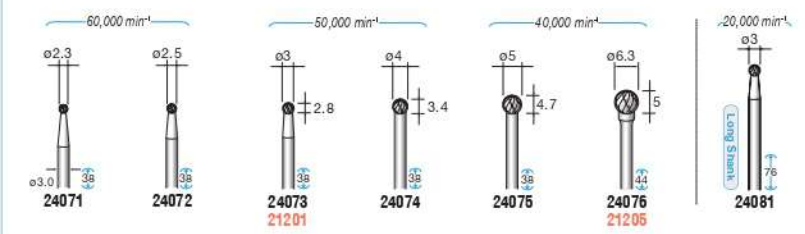

SHANK  $\phi 3.0$

1 pc./pack Single Cut

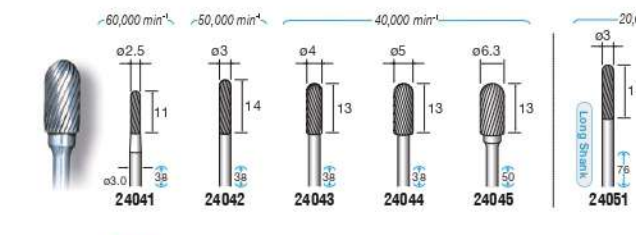

1 pc./pack Double Cut

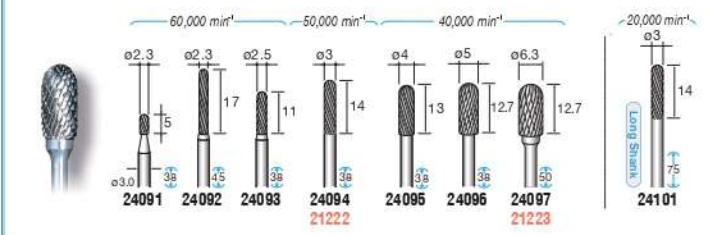

SHANK  $\phi 3.0$

1 pc./pack Single Cut

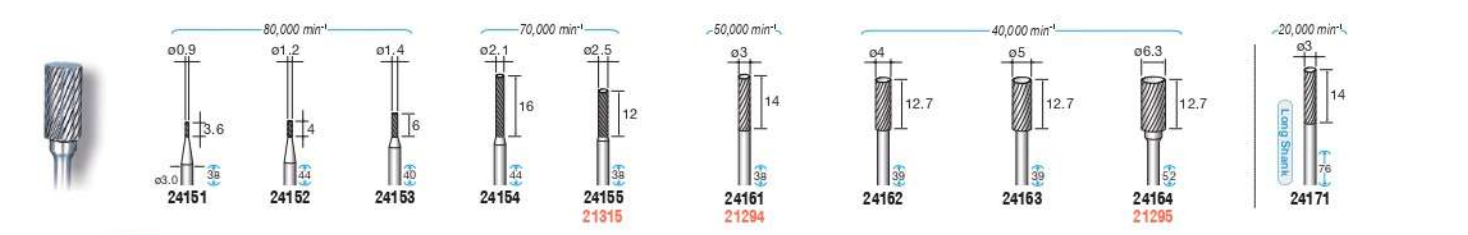

SHANK  $\phi 3.0$

1 pc./pack Single Cut End Cut

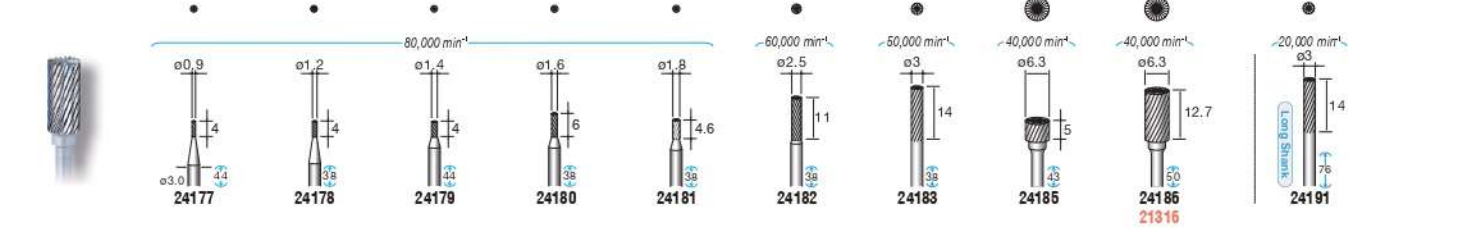

SHANK  $\phi 3.0$

1 pc./pack Double Cut

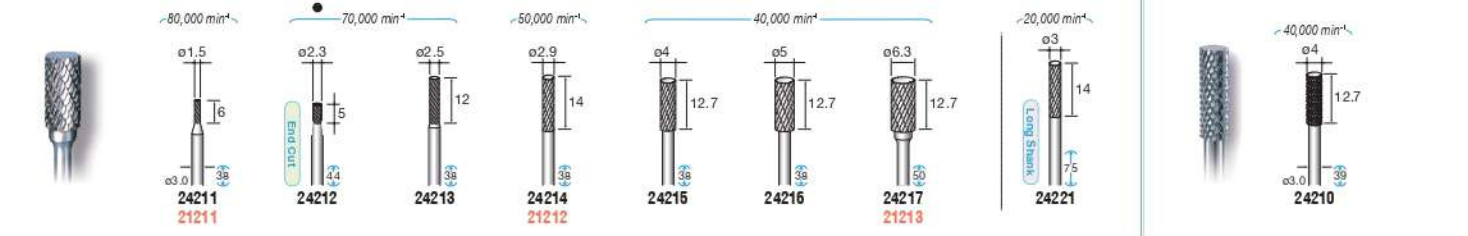

Diamond / CBN Carbide Cutters Specialty Tools Mounted Points Rubberized Abrasives Flap Wheels Polishing Brushes Felt Bobs Abrasive Compounds & Polishing Tools NSK Exclusive Tools

Diamond / CBN Carbide Cutters Specialty Tools Mounted Points Rubberized Abrasives Flap Wheels Polishing Brushes Felt Bobs Abrasive Compounds & Polishing Tools NSK Exclusive Tools



**CARBIDE CUTTERS**

• Orange code numbers indicate Titanium-Coated Type.

SHANK  $\phi 3.0$

1 pc./pack **Double Cut** **End Cut**

80,000 min<sup>-1</sup> 60,000 min<sup>-1</sup> 50,000 min<sup>-1</sup> 40,000 min<sup>-1</sup> 40,000 min<sup>-1</sup> 20,000 min<sup>-1</sup>

24231 24232 24233 24234 24235 24241

1 pc./pack **Single Cut**

50,000 min<sup>-1</sup> 40,000 min<sup>-1</sup> 20,000 min<sup>-1</sup>

24261 24262 24263 24271

SHANK  $\phi 3.0$

1 pc./pack **Single Cut**

50,000 min<sup>-1</sup> 40,000 min<sup>-1</sup> 20,000 min<sup>-1</sup>

24281 24282 24283 24284 24291

1 pc./pack **Single Cut**

50,000 min<sup>-1</sup> 40,000 min<sup>-1</sup> 20,000 min<sup>-1</sup>

24301 24302 24303 24304 24305 24311

SHANK  $\phi 3.0$

1 pc./pack **Double Cut**

50,000 min<sup>-1</sup> 40,000 min<sup>-1</sup> 20,000 min<sup>-1</sup>

24321 24322 24323 24331

1 pc./pack **Double Cut**

50,000 min<sup>-1</sup> 40,000 min<sup>-1</sup> 20,000 min<sup>-1</sup>

24341 24342 24343 24344 24351

SHANK  $\phi 3.0$

1 pc./pack **Double Cut**

60,000 min<sup>-1</sup> 50,000 min<sup>-1</sup> 40,000 min<sup>-1</sup> 20,000 min<sup>-1</sup>

24361 24362 24363 24364 24365 24366 24371

1 pc./pack **Single Cut**

50,000 min<sup>-1</sup> 40,000 min<sup>-1</sup> 20,000 min<sup>-1</sup>

24402 24403 24411

SHANK  $\phi 3.0$

1 pc./pack **Single Cut** 1 pc./pack **Single Cut** 1 pc./pack **Single Cut** 1 pc./pack **Single Cut**

40,000 min<sup>-1</sup> 40,000 min<sup>-1</sup> 60,000 min<sup>-1</sup> 50,000 min<sup>-1</sup> 40,000 min<sup>-1</sup> 20,000 min<sup>-1</sup>

24425 24435 24450 24451 24452 24453 24454 24461

SHANK  $\phi 3.0$

1 pc./pack **Single Cut** 1 pc./pack **Single Cut** 1 pc./pack **Single Cut**

60,000 min<sup>-1</sup> 50,000 min<sup>-1</sup> 40,000 min<sup>-1</sup> 50,000 min<sup>-1</sup> 40,000 min<sup>-1</sup> 40,000 min<sup>-1</sup>

24471 24472 24473 24474 24475 24476 24485 24486

**CARBIDE CUTTERS**

• Orange code numbers indicate Titanium-Coated Type.

SHANK  $\phi 3.0$

1 pc./pack **Single Cut**

50,000 min<sup>-1</sup>

24486 24497

1 pc./pack **Double Cut**

60,000 min<sup>-1</sup> 50,000 min<sup>-1</sup> 40,000 min<sup>-1</sup> 20,000 min<sup>-1</sup>

24501 24502 24503 24504 24506

1 pc./pack **Diamond Cut**

40,000 min<sup>-1</sup>

24525

SHANK  $\phi 3.0$

1 pc./pack **Double Cut**

40,000 min<sup>-1</sup>

24515

1 pc./pack **Diamond Cut**

60,000 min<sup>-1</sup>

24551

1 pc./pack **Double Cut**

50,000 min<sup>-1</sup> 40,000 min<sup>-1</sup> 20,000 min<sup>-1</sup>

24531 24532 24533 24534 24541

SHANK  $\phi 3.0$

1 pc./pack **Double Cut**

60,000 min<sup>-1</sup> 50,000 min<sup>-1</sup> 40,000 min<sup>-1</sup>

24561 24562 24563 24564 24565

1 pc./pack **Double Cut**

40,000 min<sup>-1</sup>

24572

1 pc./pack **Double Cut**

50,000 min<sup>-1</sup>

24581 24582

SHANK  $\phi 3.0$

1 pc./pack **Alloy Cut**

60,000 min<sup>-1</sup>

24611 24612 24621 24622 24623 24631 24632 24635 24636 24641 24642 24645

**End Cut**

60,000 min<sup>-1</sup>

24651 24652 24653 24654 24661 24662 24663

SHANK  $\phi 3.0$

1 pc./pack **Alloy Cut**

60,000 min<sup>-1</sup>

24646 24651 24652 24653 24654 24661 24662 24663

12 pc./pack **Assorted Set**

24601	
Set (12 pieces)	
(Each code No. one piece-pack)	
24611	24646
24612	24651
24622	24653
24623	24654
24631	24661
24632	24663

SHANK  $\phi 6.0$

1 pc./pack **Alloy Cut**

30,000 min<sup>-1</sup> 20,000 min<sup>-1</sup> 30,000 min<sup>-1</sup> 25,000 min<sup>-1</sup> 20,000 min<sup>-1</sup>

24670 24671 24672 24673 24674 24675 24676 24677 24678

30,000 min<sup>-1</sup> 20,000 min<sup>-1</sup> 30,000 min<sup>-1</sup> 25,000 min<sup>-1</sup> 20,000 min<sup>-1</sup>

24670 24671 24672 24673 24674 24675 24676 24677 24678

Diamond / CBN Carbide Cutters Speciality Tools Mounted Points Rubberized Abrasives Flap Wheels Polishing Brushes Felt Bobs Abrasive Compounds & Polishing Tools NSK Exclusive Tools



**CARBIDE CUTTERS** • Orange code numbers indicate Titanium-Coated Type.

**SHANK  $\phi 6.0$**   
**Alloy Cut**  
 1 pc./pack

**Left Handed**  
 Left handed carbide cutters. For left handed grinders and a wide variety of automated machines.

**SHANK  $\phi 3.0$**  **Left Handed**  
 1 pc./pack **Single Cut**      1 pc./pack **Double Cut**

**SHANK  $\phi 3.0$**  **Left Handed**      **SHANK  $\phi 6.0$**  **Left Handed**

1 pc./pack **Single Cut**      1 pc./pack **Double Cut**      1 pc./pack **Single Cut**      1 pc./pack **Double Cut**      1 pc./pack **Single Cut**      1 pc./pack **Double Cut**

**SHANK  $\phi 6.0$**  **Left Handed**

1 pc./pack **Single Cut**      1 pc./pack **Double Cut**

6.0 mm shank diameter series. Ideal for grinding, polishing and general finishing of large work areas.

**SHANK  $\phi 6.0$**

1 pc./pack **Single Cut**      1 pc./pack **Double Cut**

**SHANK  $\phi 6.0$**

1 pc./pack **Single Cut**      1 pc./pack **Double Cut**

**CARBIDE CUTTERS** • Orange code numbers indicate Titanium-Coated Type.

**SHANK  $\phi 6.0$**   
**Single Cut**      **End Cut**      **Double Cut**      **End Cut**  
 1 pc./pack

**SHANK  $\phi 6.0$**

1 pc./pack **Single Cut**      1 pc./pack **Double Cut**

**SHANK  $\phi 6.0$**

1 pc./pack **Single Cut**      1 pc./pack **Double Cut**

**SHANK  $\phi 6.0$**

1 pc./pack **Single Cut**      1 pc./pack **Double Cut**

**SHANK  $\phi 6.0$**

1 pc./pack **Single Cut**      1 pc./pack **Double Cut**

**SHANK  $\phi 6.0$**

1 pc./pack **Single Cut**      1 pc./pack **Double Cut**

\*Order in standard package quantities.



**CARBIDE CUTTERS** • Orange code numbers indicate Titanium-Coated Type.

**SHANK  $\phi 6.0$**

**1 pc./pack Single Cut**

**1 pc./pack Double Cut**

**SHANK  $\phi 6.0$**

**1 pc./pack Single Cut**

**1 pc./pack Double Cut**

**SHANK  $\phi 6.0$**

**1 pc./pack Single Cut**

**1 pc./pack Double Cut**

**SHANK  $\phi 6.0$**

**1 pc./pack Single Cut**

**1 pc./pack Double Cut**

**SHANK  $\phi 6.0$**

**1 pc./pack Double Cut**

**1 pc./pack Double Cut**

**1 pc./pack Double Cut**

**CARBIDE CUTTERS**

**SHANK  $\phi 6.0$**

**1 pc./pack Double Cut**

**1 pc./pack Double Cut**

**SHANK  $\phi 6.0$**

**1 pc./pack Single Cut**

**1 pc./pack Single Cut End Cut**

**1 pc./pack Single Cut**

**SHANK  $\phi 6.0$**

**1 pc./pack Single Cut**

**1 pc./pack Single Cut**

**SHANK  $\phi 3.0, \phi 6.0$**

**1 pc./pack Diamond Cut**

**1 pc./pack Diamond Cut Drill End**

**SHANK  $\phi 1.0, \phi 1.5, \phi 2.0, \phi 2.5$**

**1 pc./pack**

D= $\phi 1.0$ Length=30		D= $\phi 1.5$ Length=30		D= $\phi 2.0$ Length=38		D= $\phi 2.5$ Length=43	
d	L	d	L	d	L	d	L
0.5	4.0	0.8	6.3	1.5	11.2	2.0	12.0
0.6	4.5	0.9	7.1	1.6	12.0	2.1	12.0
0.7	5.6	1.0	9.0	1.7	12.0	2.2	12.0
		1.1	9.0	1.8	12.0	2.3	12.0
		1.2	10.0	1.9	12.0	2.4	12.0
		1.3	10.0				
		1.4	11.2				



**CARBIDE CUTTERS**

**SHANK  $\phi 3.0$**   
12 pcs./pack **Single Cut** Assorted Set



28111 Titanium Coating	
Set (12 pieces) (Each code No. one piece-pack)	
21201	21245
21205	21261
21212	21262
21213	21265
21241	21272
21242	21275

**SHANK  $\phi 6.0$**   
8 pcs./pack **Double Cut** Assorted Set



28115 Titanium Coating	
Set (8 pieces) (Each code No. one piece-pack)	
21511	21535
21512	21536
21515	21541
21516	21546

**SHANK  $\phi 2.34$**   
12 pcs./pack **Single Cut** Assorted Set



28121	
Set (12 pieces) (Each code No. one piece-pack)	
23014	23132
23017	23133
23019	23161
23022	23162
23024	23163
23131	23166

12 pcs./pack **Double Cut** Assorted Set



28125	
Set (12 pieces) (Each code No. one piece-pack)	
23403	23415
23405	23416
23407	23504
23410	23507
23412	23553
23413	23573

**SHANK  $\phi 3.0$**   
12 pcs./pack **Single Cut** Assorted Set



28141	
Set (12 pieces) (Each code No. one piece-pack)	
24016	24301
24019	24303
24041	24305
24044	24402
24161	24452
24164	24454

12 pcs./pack **Double Cut** Assorted Set



28145	
Set (12 pieces) (Each code No. one piece-pack)	
24073	24362
24076	24364
24093	24366
24096	24504
24214	24532
24217	24534

**SHANK  $\phi 6.0$**   
8 pcs./pack **Single Cut** Assorted Set



28171	
Set (8 pieces) (Each code No. one piece-pack)	
26011	26111
26031	26131
26071	26151
26091	26171

8 pcs./pack **Single Cut** Assorted Set



28175	
Set (8 pieces) (Each code No. one piece-pack)	
26013	26113
26033	26133
26073	26153
26092	26172

**SHANK  $\phi 6.0$**   
8 pcs./pack **Double Cut** Assorted Set



28181	
Set (8 pieces) (Each code No. one piece-pack)	
26021	26121
26041	26141
26081	26161
26101	26181

8 pcs./pack **Double Cut** Assorted Set



28185	
Set (8 pieces) (Each code No. one piece-pack)	
26023	26123
26043	26143
26083	26163
26102	26182

**SHANK  $\phi 3.0$**   
12 pcs./pack **Alloy Cut** Assorted Set



24601	
Set (12 pieces) (Each code No. one piece-pack)	
24611	24646
24612	24651
24622	24653
24623	24654
24631	24661
24632	24663

1 pc./pack **Wood Case**



**SPECIALTY TOOLS**



High Speed Steel(H.S.S.)Cutters.  
For cutting of general steels,  
light metals, non-metals, plastics,  
resins, etc.

**SHANK  $\phi 3.0$**   
1 pc./pack

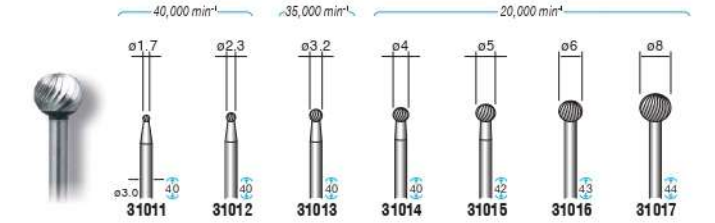

**SHANK  $\phi 3.0$**   
1 pc./pack



**SHANK  $\phi 3.0$**   
1 pc./pack

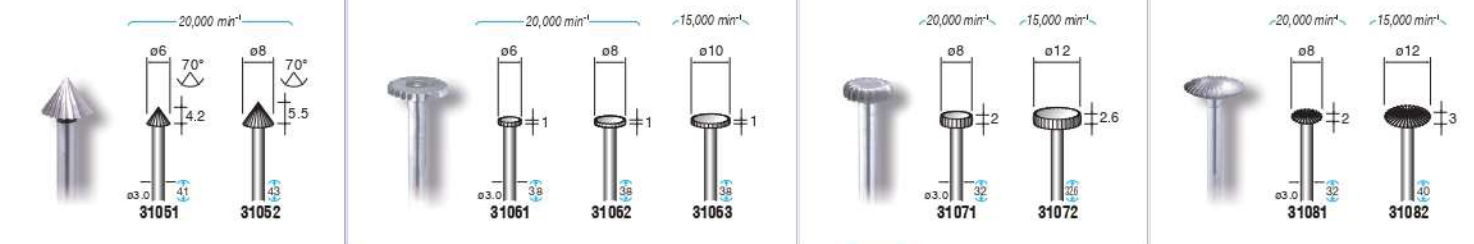

Tungsten Vanadium Steel Cutters.  
For fine finishing of soft materials,  
resins, bronze, acrylics, etc.

**SHANK  $\phi 2.34$**   
12 pcs./pack

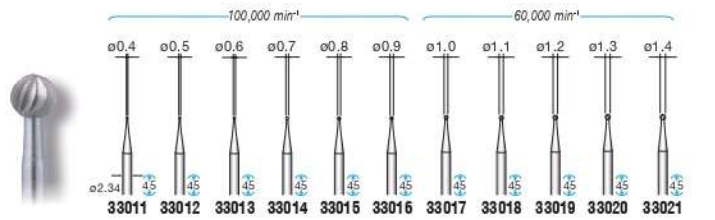

**SHANK  $\phi 2.34$**   
12 pcs./pack

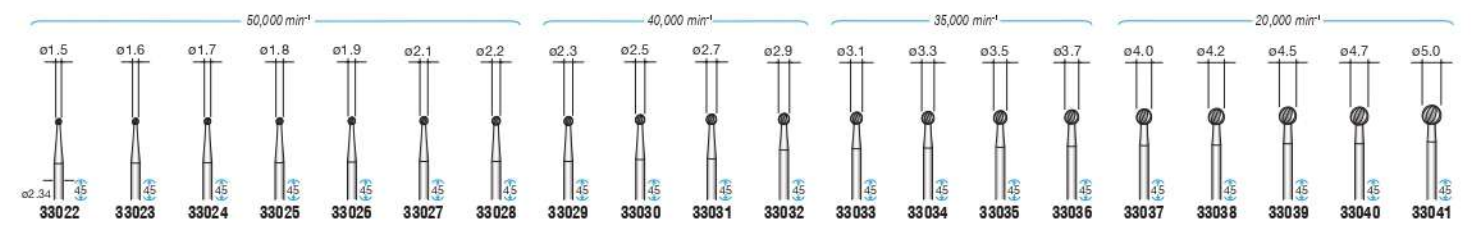

**SHANK  $\phi 2.34$**   
12 pcs./pack

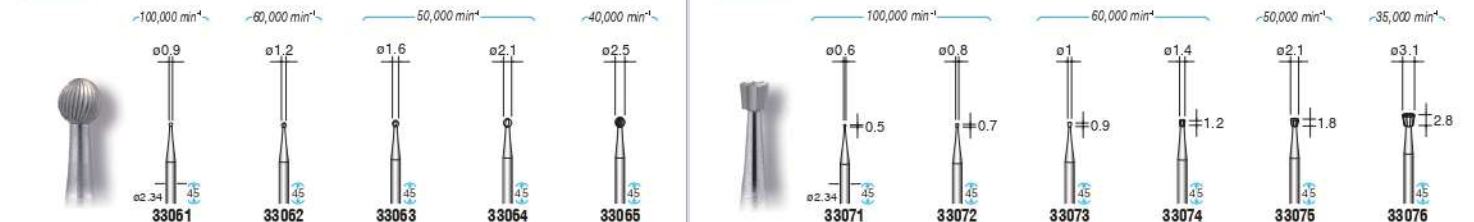

Diamond / CBN  
Carbide Cutters  
Specialty Tools  
Mounted Points  
Rubberized Abrasives  
Flap Wheels  
Polishing Brushes  
Felt Bobs  
Abrasive Compounds & Polishing Tools  
NSK Exclusive Tools

Diamond / CBN

Carbide Cutters

Specialty Tools

Mounted Points

Rubberized Abrasives

Flap Wheels

Polishing Brushes

Felt Bobs

Abrasive Compounds & Polishing Tools

NSK Exclusive Tools

Diamond / CBN

Carbide Cutters

Specialty Tools

Mounted Points

Rubberized Abrasives

Flap Wheels

Polishing Brushes

Felt Bobs

Abrasive Compounds & Polishing Tools

NSK Exclusive Tools

Diamond / CBN

Carbide Cutters

Specialty Tools

Mounted Points

Rubberized Abrasives

Flap Wheels

Polishing Brushes

Felt Bobs

Abrasive Compounds & Polishing Tools

NSK Exclusive Tools

Diamond / CBN

Carbide Cutters

Specialty Tools

Mounted Points

Rubberized Abrasives

Flap Wheels

Polishing Brushes

Felt Bobs

Abrasive Compounds & Polishing Tools

NSK Exclusive Tools

Diamond / CBN

Carbide Cutters

Specialty Tools

Mounted Points

Rubberized Abrasives

Flap Wheels

Polishing Brushes

Felt Bobs

Abrasive Compounds & Polishing Tools

NSK Exclusive Tools

Diamond / CBN

Carbide Cutters

Specialty Tools

Mounted Points

Rubberized Abrasives

Flap Wheels

Polishing Brushes

Felt Bobs

Abrasive Compounds & Polishing Tools

NSK Exclusive Tools

Diamond / CBN

Carbide Cutters

Specialty Tools

Mounted Points

Rubberized Abrasives

Flap Wheels

Polishing Brushes

Felt Bobs

Abrasive Compounds & Polishing Tools

NSK Exclusive Tools

Diamond / CBN

Carbide Cutters

Specialty Tools

Mounted Points

Rubberized Abrasives

Flap Wheels

Polishing Brushes

Felt Bobs

Abrasive Compounds & Polishing Tools

NSK Exclusive Tools

Diamond / CBN

Carbide Cutters

Specialty Tools

Mounted Points

Rubberized Abrasives

Flap Wheels

Polishing Brushes

Felt Bobs

Abrasive Compounds & Polishing Tools

NSK Exclusive Tools

Diamond / CBN